

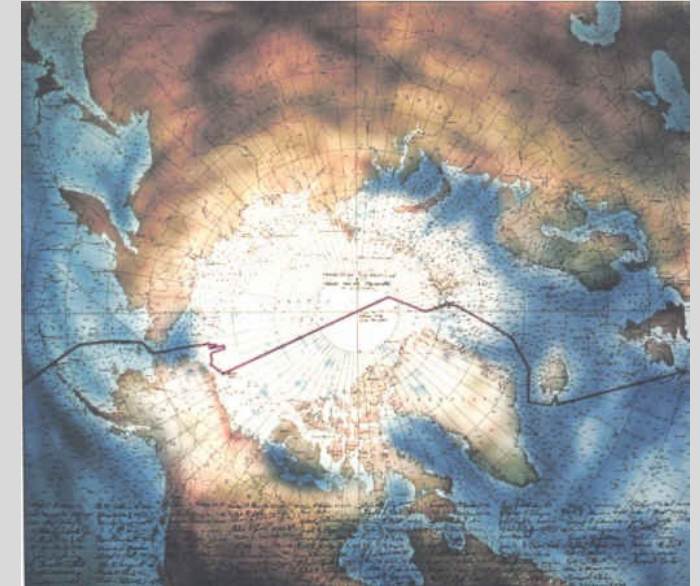

Space Nuclear Technology: R&D for Evolving Space Missions

Franklin Chang Díaz
Ad Astra Rocket Company
141 W. Bay Area Blvd, Webster TX 77598
March 21, 2024

1958 Nautilus Sails Under North Pole



The Nautilus Paradigm

(First nuclear-electric ship transformed underwater transport)

Like Nautilus at sea, space nuclear power enables the transportation paradigm shift needed to enable humans to truly become a space-faring species

Space Propulsion: The Big Picture

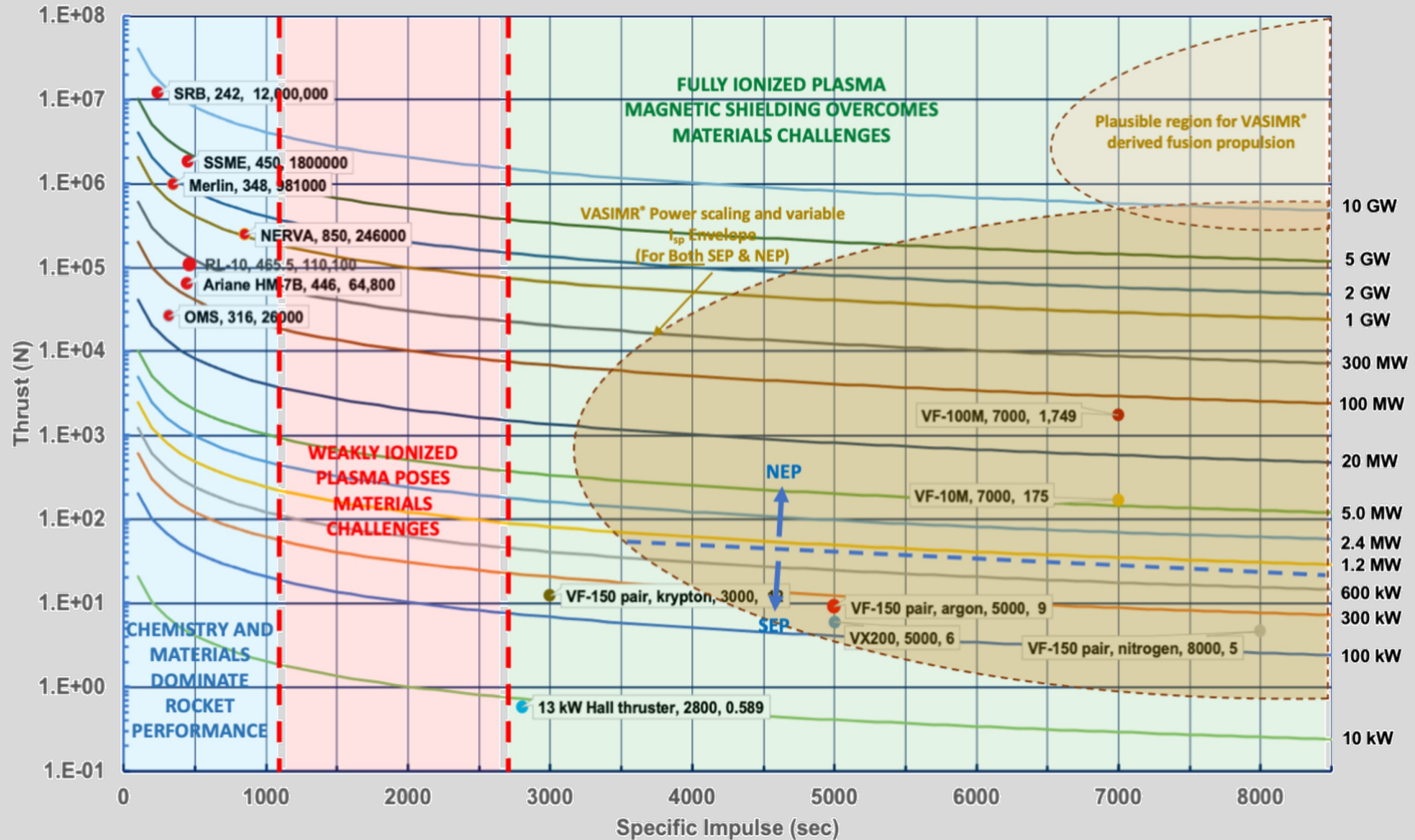

VASIMR[®] is an Electromagnetic Thruster

- Three separate but interconnected magnetic stages produce, heat and accelerate a plasma
- **The first stage** is a "Helicon" type plasma discharge that efficiently ionizes the propellant
- **The second stage** energizes the plasma ions by Ion Cyclotron Resonance Heating (ICRH)
- **The Magnetic Nozzle** accelerates the ions by converting their perpendicular cyclotronic motion to axial motion and hence thrust
- Magnetic field insulates rocket from extreme temperature
- No electrodes to erode away
- Plasma is quasi neutral, ions and electrons flow together, so no need for a neutralizer

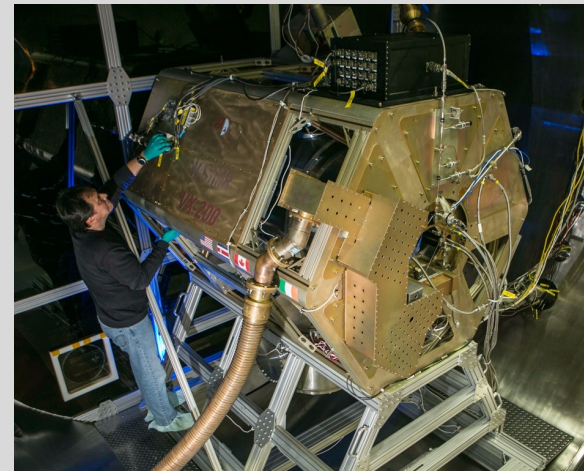
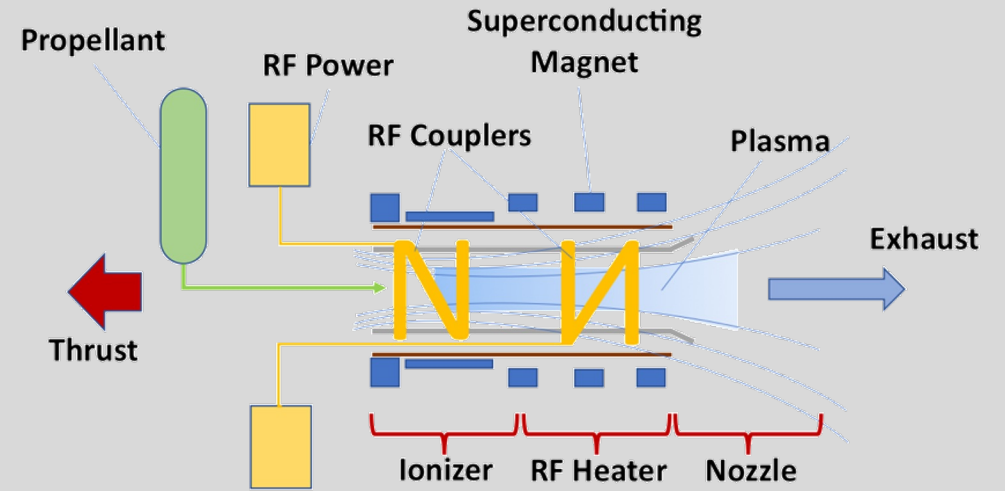

One-way Mars Transits with High Power NEP

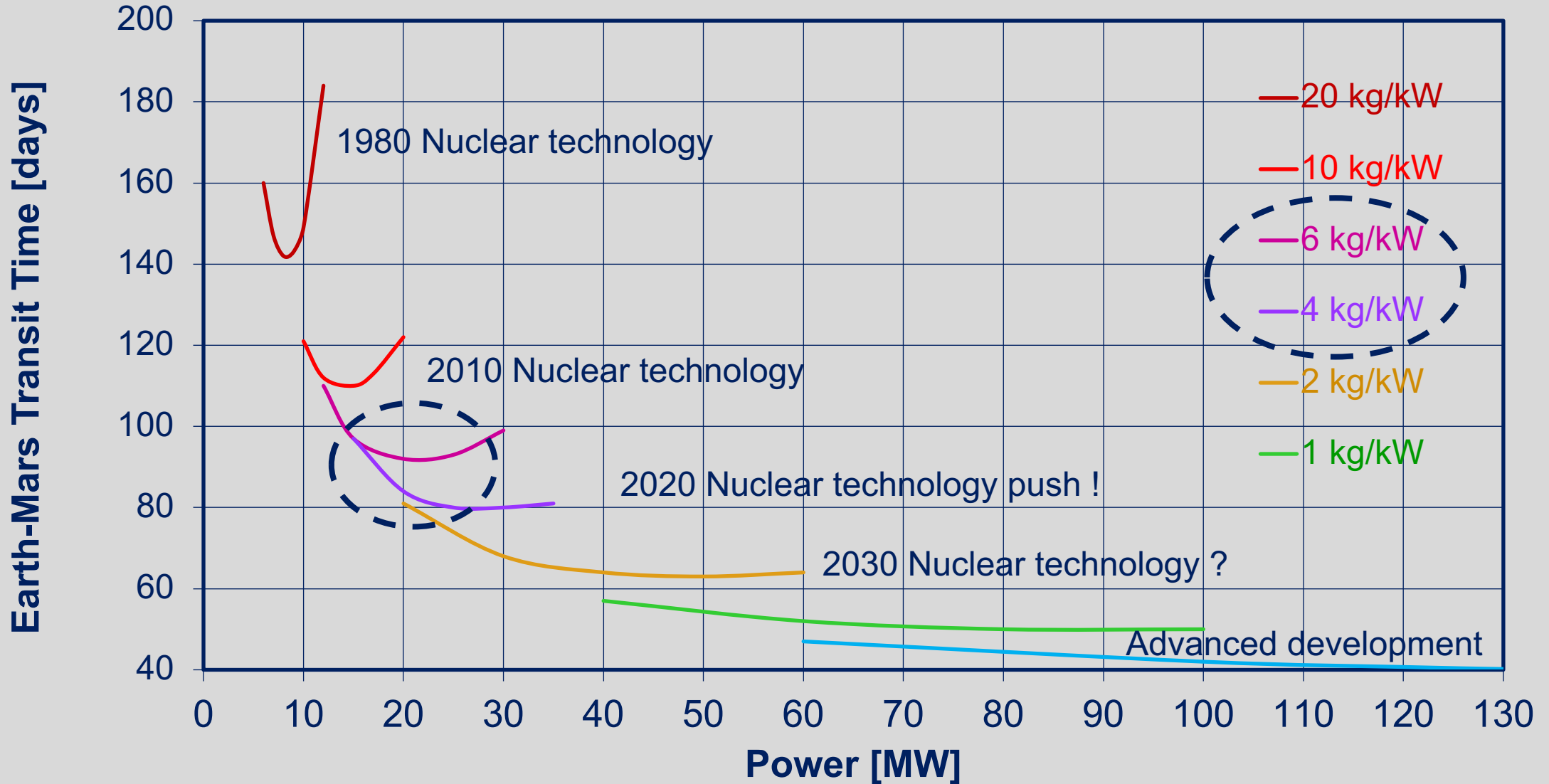

High Power NEP vs NTP Departure Window

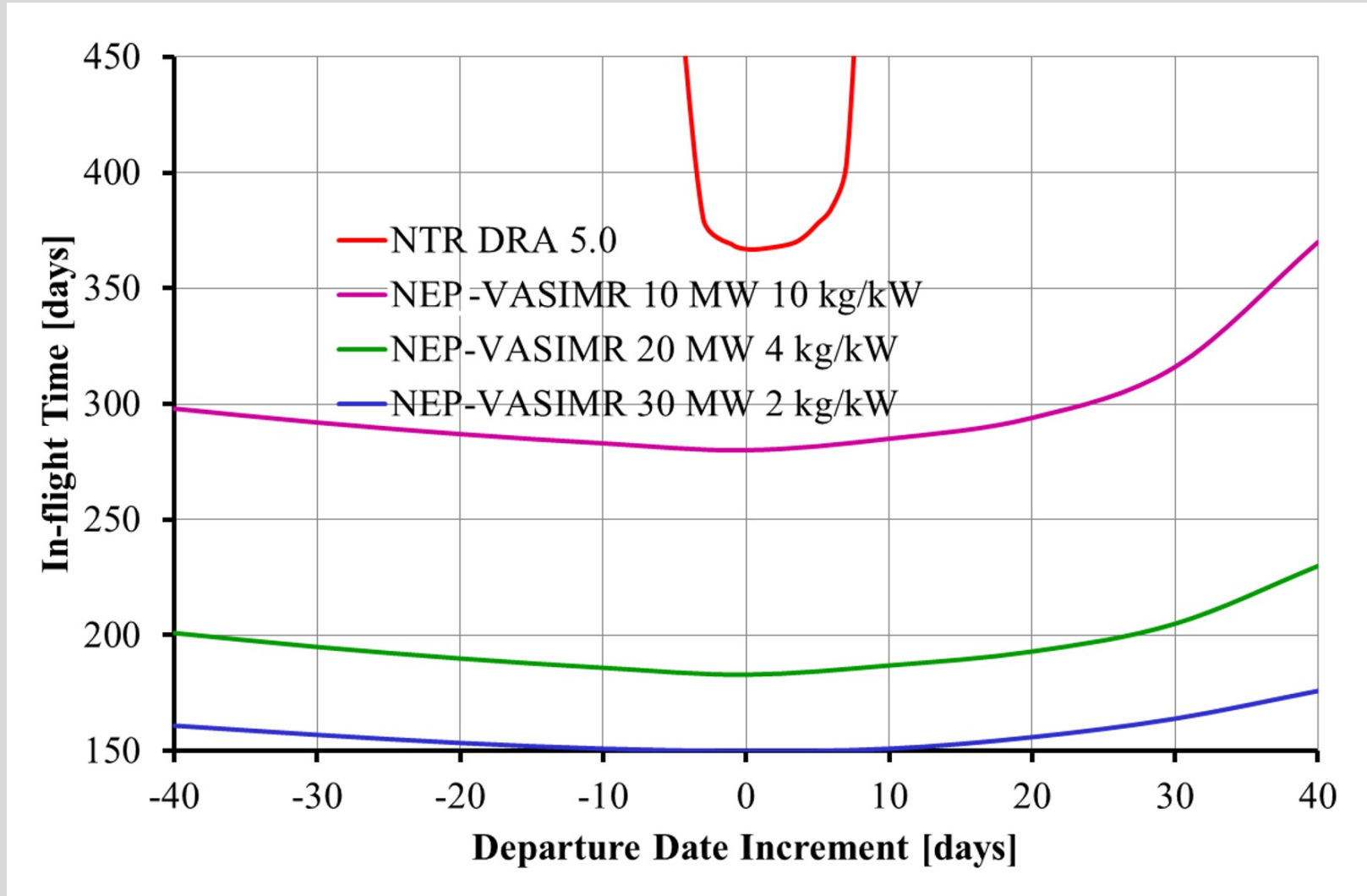

Notional NEP Human Mars Ship With Radiation Shielding

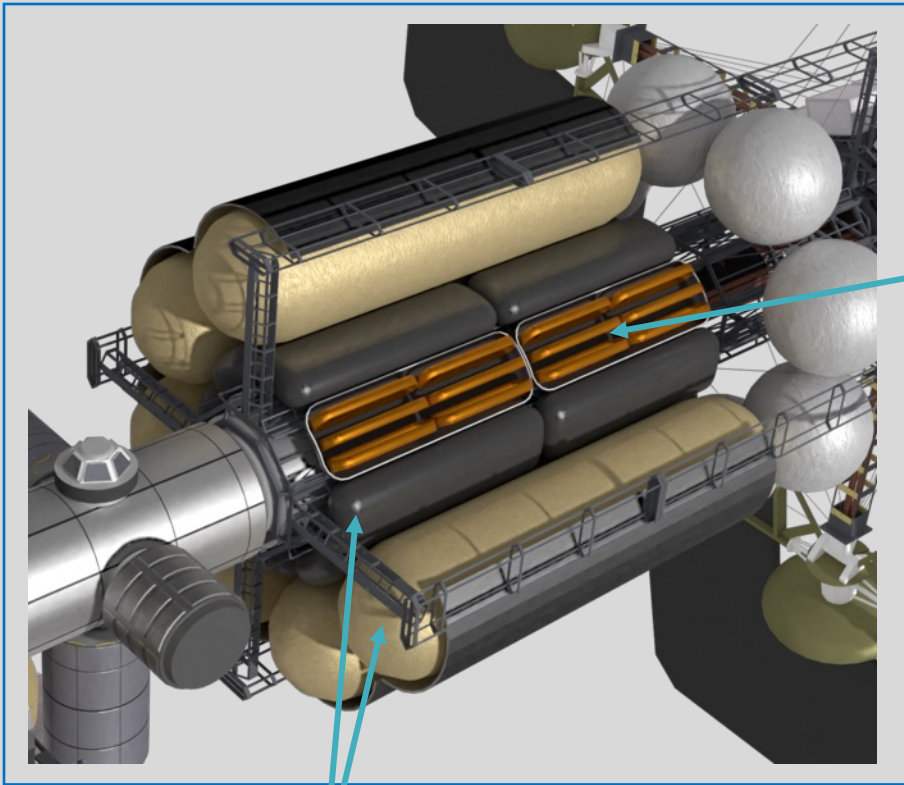

Liquid Hydrogen Propellant
(primary shield)

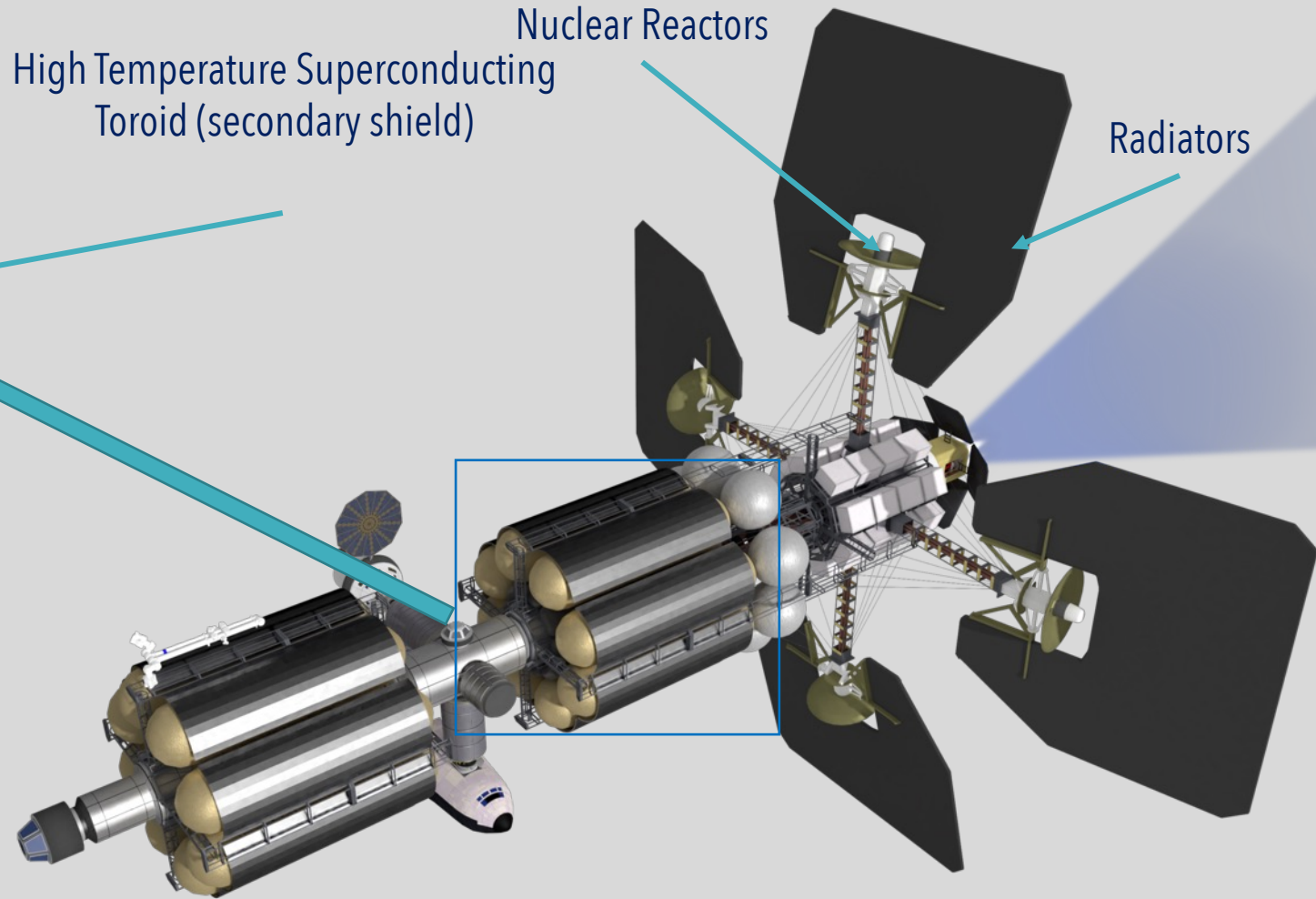

Notional NEP Mission Parameters

- Departure date: May 20, 2035
- Payload: 62 t
- Stay on Mars: 30 days
- Tank/Propellant ratio: 10%
- Power: 40 MW
- System efficiency: 70%
- Total specific mass: 2 - 4 kg/kW
- Departure: $IM_{L1} = 300 - 600$ t
- Variable I_{sp} range: [2000; 30,000] sec
- Arrival: Medium Mars Orbit (20,000 km)
- Relative velocity: 10 km/s at Mars atmosphere

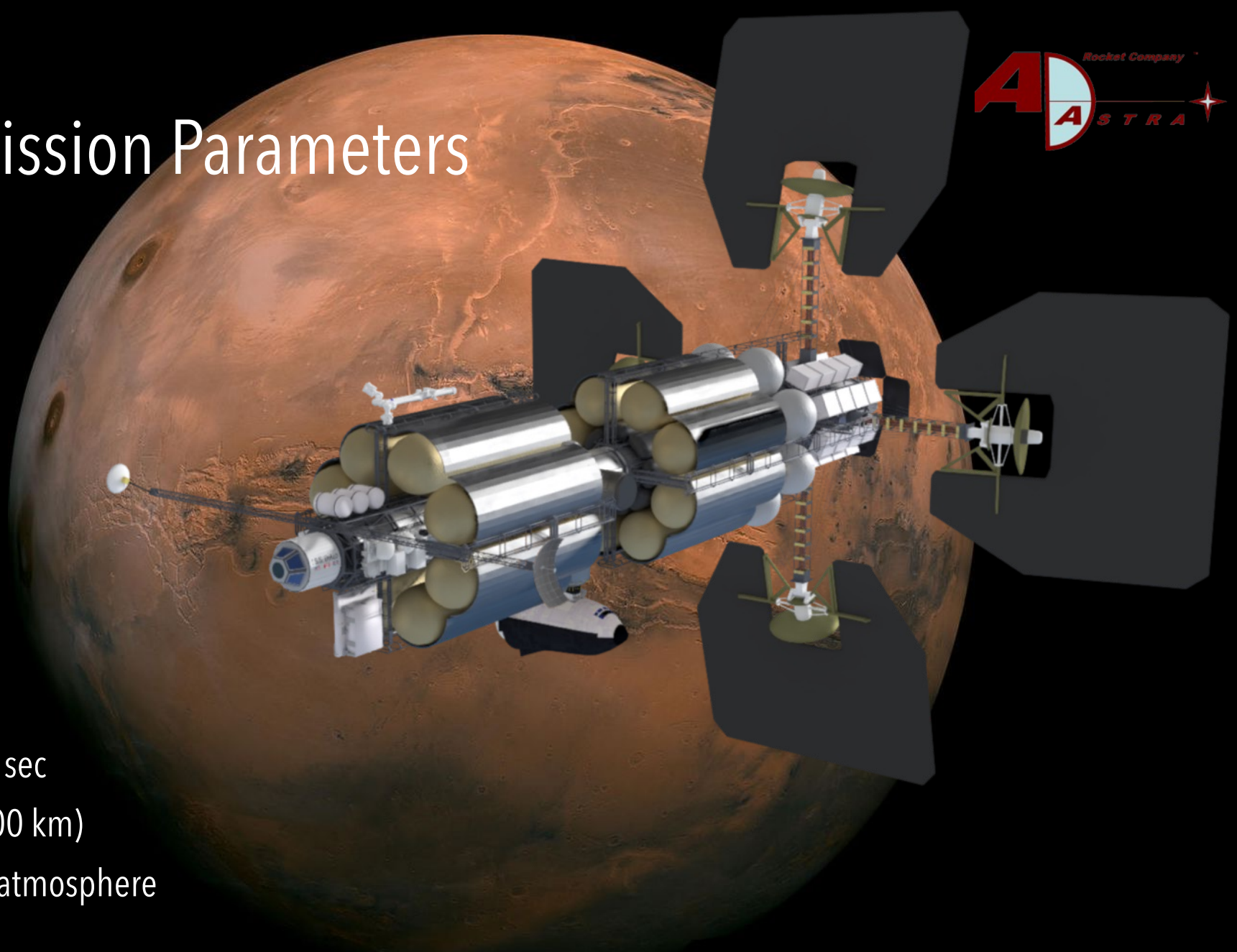

95 Days to Mars

1. L1-ESOI, 6d, $I_{sp} = 3000$ sec, Prop = 36 t
2. ESOI-MSOI, 89d, $I_{sp} = \text{var}$, Prop = 112 t
3. Mars arrival, Lander aerobrakes $V_{arr} = 10$ km/sec
4. OTV returns to MSOI, 30d, Prop 26 t
5. OTV spiral to MMO, 6d, $I_{sp} = 7000$ sec, Prop = 6 t
6. After 36 days on Mars, CRV docks with OTV and departs MMO - MSOI, 5d, Prop = 15 t $I_{sp} = 4000$ sec
7. MSOI - ESOI, 95d, Prop = 41 t $I_{sp} = \text{var}$

Definitions

ESOI:	Earth Sphere of Influence
MSOI:	Mars Sphere of Influence
OTV:	Orbit Transfer Vehicle
CRV:	Crew Return Vehicle
MMO:	Medium Mars Orbit

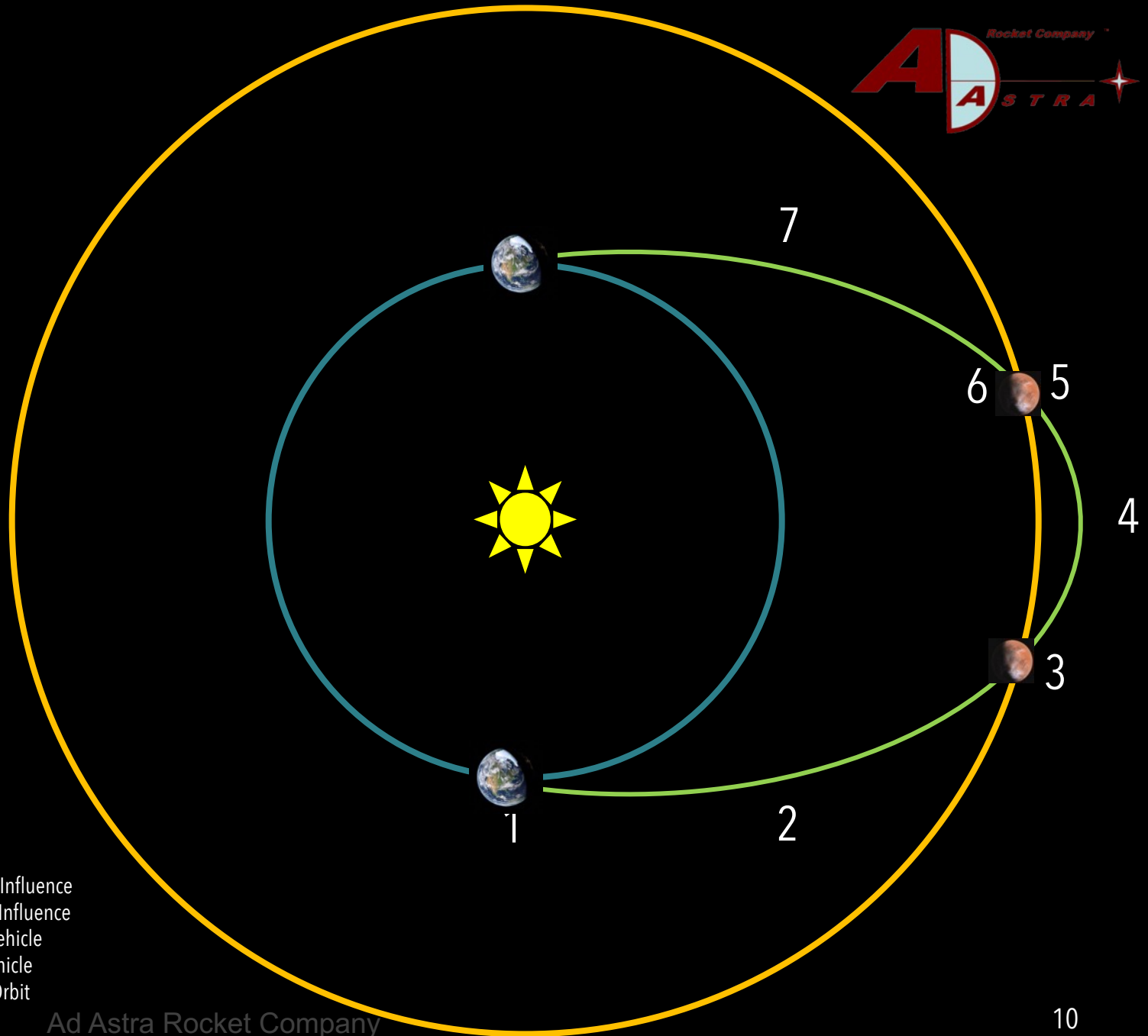

Nuclear Electric

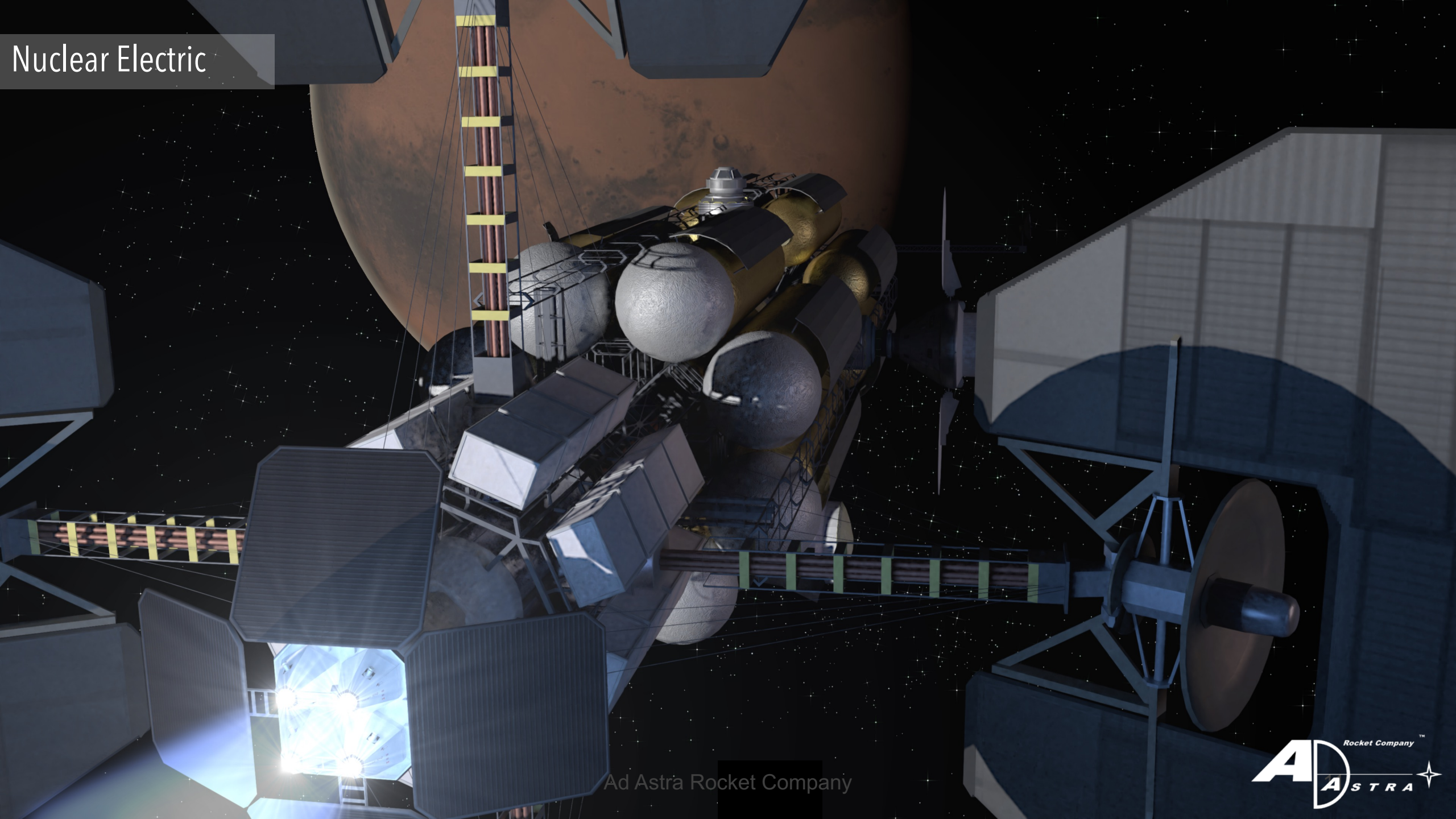

Ad Astra Rocket Company





Thank You!